



MORCO MODELS D-61B, D-61E AND G11E



INDEX

A.- ENGLISH

A.1. INSTRUCTIONS FOR USERS	5
A.2. TECHNICAL INSTRUCTIONS FOR INSTALLATION ENGINEERS	8
A.2.1. TECHNICAL INFORMATION	8
A.2.2. INSTALLATION INSTRUCTIONS	13
A.2.3. LOOKING AFTER THE APPLIANCE.....	17
A.2.4. SYMBOLS	18
A.2.5. TROUBLE SHOOTING	18
A.2.6. WARRANTY	22

B.- FRANÇAIS

B.1. INSTRUCTIONS POUR LES UTILISATEURS	24
B.2. INSTRUCTIONS TECHNIQUES POUR L'INSTALLATEURS	27
B.2.1. DONNÉES TECHNIQUES	27
B.2.2. NORMES D'INSTALLATION	32
B.2.3. ENTRETIEN DE L'APPAREIL.....	36
B.2.4. SYMBOLES	38
B.2.5. DÉPANNAGE.....	38
B.2.6. GARANTIE.....	42

C.- NEDERLANDS

C.1. INSTRUCTIES VOOR GEBRUIKERS	44
C.2. TECHNISCHE INSTRUCTIES VOOR INSTALLATIETECHNICI.....	47
C.2.1. TECHNISCHE INFORMATIE.....	47
C.2.2. INSTRUCTIES VOOR DE INSTALLATIE.....	52
C.2.3. ONDERHOUD VAN HET TOESTEL	57
C.2.4. SYMBOLEN.....	58
C.2.5. PROBLEEMOPLOSSING	58
C.2.6. GARANTIE	62

MORCO MODELS D-61B, D61E AND G11E

IMPORTANT INFORMATION

INSTANTANEOUS MULTI-POINT WATER HEATER

FITTED WITH DRAUGHT DIVERTER

FOR NORMAL OPEN FLUED SYSTEM

THIS HEATER IS MANUFACTURED IN ACCORDANCE WITH EN 26

NOTE: THIS APPLAINCE IS ADJUSTED FOR USE ON LIQUEFIED PETROLEUM GAS ONLY (BUTANE AND PROPANE GAS)

BEFORE USING THIS APPLIANCE PLEASE READ THESE INSTRUCTIONS THOROUGHLY, ALWAYS RETAIN THE INSTRCTIONS FOR FUTURE USE.

GAS SAFETY (INSTALLATION AND USE) REGULATIONS 1998

IN THE INTEREST OF SAFETY, IT IS THE LAW THAT ALL GAS APPLIANCES ARE INSTALLED AND SERVICED BY A COMPETENT PERSON IN ACCORDANCE WITH THE ABOVE REGULATIONS, BUILDING REGULATIONS, CODES OF PRACTICE AND BYELAWS OF THE LOCAL WATER UNDERTAKING.

FAILURE TO COMPLY WITH THE REGULATIONS MAY LEAD TO PROSECTION. IT IS IN YOUR INTERESTS AND THAT OF SAFETY THAT THE LAW IS COMPLIED

A.1. - INSTRUCTIONS FOR USERS

Technical instructions for use and maintenance

WARNING: Before use, this appliance must be installed and adjusted by a competent person according to the technical instructions in this manual. No attempt must be made to adjust this appliance for use with other gases.

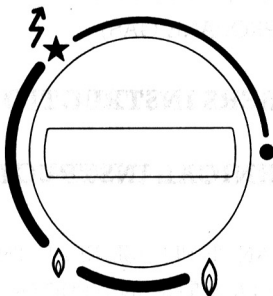

• LIGHTING THE PILOT

- Fully depress the control knob and turn it to the left from the ● position to the position (pilot setting).
- The pilot should light during this operation due to the action of the piezoelectric spark igniter or electronic ignition.
- Hold this knob in this position for about 10 seconds after the pilot has lit.

If the pilot fails to light after having activated the piezoelectric spark igniter mechanism or electronic ignition, this means that there is air in the gas pipes. In this case, allow plenty of time for the pipes to be cleared of air, with the gas control knob at the pilot setting. ★ Where there are long gas pipe runs, it may take up to 3 minutes.

• PREPARING THE HEATER FOR USE

Once the pipes are free of air and the pilot is alight, wait about 10 seconds for the safety valve mechanism to be activated, the appliance is ready for use.

Turn the control knob anti – clockwise to one of the main burner settings. 🔥 🔥

• GAS CONSUMPTION SELECTION

You can choose between two different types of operation, depending on the hot water outlet temperature required.

Economy Setting

Turn the control knob to the 🔥 position.

Use this setting only when the ambient cold water supply to the heater temperature is high (Normally summer continental use)

Full power setting (for normal use) 🔥

Use this setting when the ambient cold water supply to the heater is low (Normally UK or cold climate countries)

• WATER TEMPERATURE SELECTION

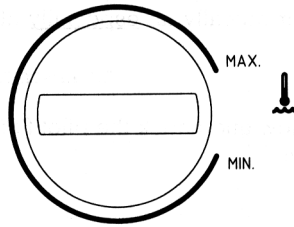

To adjust the hot water temperature, turn the selector control to the right for hotter water and to the left for cooler water.

- Whatever the water temperature selected, it remains constant even if there are fluctuations in the mains water pressure, (within the minimum and maximum range), due to the action of the automatic water flow regulator.
- Never reduce the flow of hot water by using the appliance's water inlet stopcock. This stopcock should always be fully open.

• TURNING OFF THE WATER HEATER

From whichever position the gas control knob is in, turn it to the right to the ● position. This will cut off the supply of gas to the pilot and the burner.

• PRECAUTIONS TO BE TAKEN AGAINST FROST AND FREEZING CONDITIONS

If the appliance is installed in caravan holiday home, leaving the appliance un-drained during freezing conditions, will result in the appliance being frost damaged. It must be drained down in the following way:

- Turn off the mains water inlet stopcock.
- Turn temperature control knob fully anticlockwise to minimum setting.
- Turn on all hot and cold water taps.
- Open all hot and cold drain cocks on the installation. Please refer to your caravan owners handbook for the location of all drain cocks.
- Disconnect the mains water inlet stopcock from the caravan pipework, this will stop water refilling the pipework, if the stopcock fails due to frost damage.
- Protect drain cocks and any open ended pipe from insects or debris.

To turn the water on again, close all drain cocks, reconnect and open the mains water inlet stopcock and turn off each hot and cold water taps as the water runs clear.

We strongly recommend a qualified & competent service engineer is employed to do the drain down service.

MAINTENANCE RECOMMENDATIONS

The appliance must be checked for safe operation annually, regardless of frequency of use. This refers principally to the correct combustion of the main burner and pilot. Maintenance should only be carried out by a qualified and competent service engineer. Please refer to section 2.3 of this manual.

• CHECKING FOR SAFE OPERATION

In addition to any annual service by a competent person, the user should carry out the following checks periodically and especially after any period of disuse.

• PILOT BURNER

Look through the pilot window and check the pilot flame is blue. There should be no yellow colour or laziness.

• MAIN BURNER

Look through the pilot window when the hot tap is open and the boiler is running. The burner flames should be all blue with no yellow/white colour or laziness.

If you see any yellowness or laziness in the flames do not use the appliance and call a service engineer. The burners will almost certainly be blocked by dust/fluff or insect matter and any further use will cause sooting up leading to a dangerous situation and expensive repair.

• OTHER INDICATIONS

- Never tamper or adjust with any pre-sealed unit.
- There is a danger of burning yourself if you touch the area in or around the pilot window. We recommend that you avoid touching this area.
- Do not cover or use the heater for drying purposes or use the heater compartment for storage of any goods especially flammable liquids.
- The appliance has a device to detect that combustion gases are removed correctly via the flue. If there are any problems detected in the removal of these gases (spillage), the device cuts off the supply of gas to the burner
N.B. Adverse weather conditions may cause this device to activate please See section A.2.2 COMBUSTION GAS REMOVAL

To restart the appliance you must wait at least 10 minutes before lighting the pilot light, as described earlier.

If these interruptions occur repeatedly have the heater inspected by a competent registered gas engineer.

NEVER BLOCK ANY VENTILATION THAT HAS BEEN PURPOSELY PROVIDED FOR THE CORRECT AND SAFE OPERATION OF THE APPLIANCE.

A.2.- TECHNICAL INSTRUCTIONS FOR INSTALLATION ENGINEERS

A.2.1. TECHNICAL INFORMATION

- Shape and outer dimensions

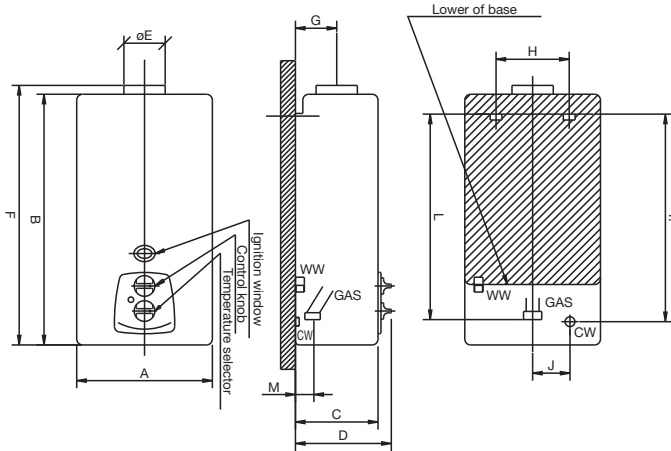

	A	B	C	D	E	F	G	H	I	J	L	M
G11E	310	634	230	276	110	660	115	235	464	50	456	45
D61B/D61E	266	573	190	236	90	589	97	120	350	50	344	45

• SPECIFICATIONS

- Available calorific power

MODELS	D61B - D61E	G11E
Maximum	9,4 kW (135 kcal/min.)	19,2 kW (275 kcal/min.)
Minimum	5,6 kW (81 kcal/min.)	10 kW (145 kcal/min.)

- Output in terms of a p.c.i. over 85%

• HOT WATER DELIVERY

The figures quoted are for the appliance at normal operating pressure at minimum and maximum selector settings.

NOTE: Temperatures are in degrees rise above ambient.

MODELS	SELECTOR SETTING			
	OPEN		CLOSED	
	Water flow	T	Water flow	T
D61B-D61E	5,4 litres/min.	25°C	2,7 litres/min.	50°C
G11E	11 litres/min.	25°C	5,5, litres/min.	50°C

• OPERATING PRESSURE

- **Minimum** 1bar • **Maximum** 10 bar
- Water inlet pressure with the appliance working at normal pressure.

• GAS CONSUMPTION

TYPE OF GAS (Standardised gases)	GAS FLOW AT 15°C and 760 mm Hg		GAS PRESSURE AT APPLIANCE INLET (mbar)
	G11E	D61B-D61E	
Butane	1,8 kg/h.	0,88 kg/h.	28-30
Propane	1,8 kg/h.	0,88 kg/h.	37
Natural	2,3 m ³ /h.	1,2 m ³ /h.	20-25

• BURNER PRESSURE

TYPE OF GAS (Standardised gases)	G11E	D61B-D61E
Butane	27,5 mbar	29 mbar
Propane	36,3 mbar	36,9 mbar
Natural gas	16,4 mbar	19,4 mbar

• BURNT GAS FLOW AND SMOKE TEMPERATURES

MODELS	G11E	D61B-D61E
Flow g/s	13	7,8
Temperature	160°C	137°C

• AIR FLOW NECESSARY FOR THE COMBUSTION

TYPE OF GAS (Standardised gases)	G11E	D61B-D61E
Butane (1Kg.)	20,31 m ³ /h.	10,75 m ³ /h.
Propane (1Kg.)	20,63 m ³ /h.	10,92 m ³ /h.
Natural gas (1 m ³)	23,27 m ³ /h.	12,14 m ³ /h.

• PIPE WORK DIAMETERS AND CONNECTION SIZES

PIPE WORK		CONNECTION SIZES
GAS	Butane/Propane-Natural	10 or 15 mm.
WATER	Inlet (cold)	15 mm.
	Outlet (hot)	15 mm.
Flueway	D61B and D61E	ø 90 mm.
	G11E	ø 110 mm.

• **DESCRIPTION AND OPERATION**

- These gas water heaters are equipped with:
- A stainless steel burner which can operate with Butane/Propane-Natural.
- A pilot which will operate with either Butane/Propane. Ignition is by piezoelectric or by the battery powered electronic spark ignition.
- A fully automatic soft start ignition system which needs no adjusting. This prevents any black smoke being given off during the main burner ignition process.
- A thermocouple safety valve which shuts off the gas supply to both pilot and main burner in the event of accidental flame failure.
- An inter-ignition valve which cuts off the supply of gas to the burner during the pilot ignition process, even if there is water circulating through the appliance.
- A total shut-off valve which shuts off the supply of gas to the burner and the pilot, even during the response time before the safety valve closes.
- A water valve which modulates the supply of gas to the burner in proportion to the flow of water through the appliance.
- A gas economy feature which enables the supply of gas to the burner to be reduced by up to 60%, this function can be used when the ambient temperature of the water supply is high.
- An automatic water flow regulator to provide a constant flow rate at the tap at varying pressures (Min supply pressure 1.0b Max supply pressure 10.0b)
- A water temperature selector.
- A heat exchanger made from pure electrolytic copper.
- A draught diverter hood.

OPERATION

Once the appliance has been turned on following the procedure given in section A.2.2.B "Instructions for starting up the appliance" gas is supplied to the burner whenever a hot water tap is turned on.

As water flows through the appliance a pressure differential is created within the water control assembly. This in turn will cause the diaphragm and push rod to lift opening the main burner gas valve

When the hot water tap is turned off, the water flow through the appliance ceases, and the pressure differential created in the water control assembly diminishes returning the diaphragm and push rod to the no flow position. This will allow the main burner gas valve to close.

Whilst the appliance is in operation, even if there are pressure fluctuations in the mains supply providing these fluctuations are within the minimum and maximum operating pressures, the temperature of the water is maintained at all times at the selected temperature due to the action of the "automatic water flow regulator"

MORCO INSTANTANEOUS GAS WATER HEATER		CE 0099 99AT507	
Mod. N°:	D61B		
Gas Type:	G-30 G-31	28mbar 37mbar	Cat. I ₃₊ 30mbar Cat. I _{3B/P}
Type:	B _{11B5}		
Qn (hi)	11,1 kW		
Qm (hi)	6,6 kW	R. Fab. 20/26210	
Pn	9,4 kW	SERIAL N°	
Pw	10 bar		
Cat.	I ₃₊	I _{3B/P}	NL
Country/Pays:	GB / FR / IE / IT / ES / BE		
USE ONLY IN WELL VENTILATED ROOMS NOT TO BE INSTALLED IN BATHROOMS			
MORCO PRODUCTS LTD Morco House Riverview Road Beverley HU17 OLD ENGLAND			

MORCO INSTANTANEOUS GAS WATER HEATER		CE 0099 99AT507	
Mod. N°:	D61E		
Gas Type:	G-30 G-31	28mbar 37mbar	Cat. I ₃₊ 30mbar Cat. I _{3B/P}
Type:	B _{11B5}		
Qn (hi)	11,1 kW		
Qm (hi)	6,6 kW	R. Fab. 20/26210	
Pn	9,4 kW	SERIAL N°	
Pw	10 bar		
Cat.	I ₃₊	I _{3B/P}	NL
Country/Pays:	GB / FR / IE / IT / ES / BE		
USE ONLY IN WELL VENTILATED ROOMS NOT TO BE INSTALLED IN BATHROOMS			
MORCO PRODUCTS LTD Morco House Riverview Road Beverley HU17 OLD ENGLAND			

MORCO INSTANTANEOUS GAS WATER HEATER		CE 0099 99BP819	
Mod. N°:	G1E PROP		
Gas Type:	G-30/G31 G-30	28-30mbar 37mbar	Cat. I ₃₊ 30mbar Cat. I _{3B/P}
Type:	B _{11B5}		
Qn (hi)	22,6 kW		
Qm (hi)	11,8 kW	R. Fab. 20/26210	
Pn	19,2 kW	SERIAL N°	
Pw	10 bar		
Cat.	I ₃₊	I _{3B/P}	NL
Country/Pays:	BE / ES / FR / GB / IE / IT / PT		
USE ONLY IN WELL VENTILATED ROOMS NOT TO BE INSTALLED IN BATHROOMS			
MORCO PRODUCTS LTD Morco House Riverview Road Beverley HU17 OLD ENGLAND			

MORCO INSTANTANEOUS GAS WATER HEATER		CE 0099 99BP819	
Mod. N°:	G1E NAT		
Gas Type:	G-20 G-20/G25	20mbar	Cat. I _{2H} 20mbar Cat. I _{2E+} 25mbar
Type:	B _{11B5}		
Qn (hi)	22,6 kW		
Qm (hi)	11,8 kW	R. Fab. 20/26210	
Pn	19,2 kW	SERIAL N°	
Pw	10 bar		
Cat.	I _{2H}	I _{2E+}	BE / FR
Country/Pays:	ES / GB / IE / IT / PT		
USE ONLY IN WELL VENTILATED ROOMS NOT TO BE INSTALLED IN BATHROOMS			
MORCO PRODUCTS LTD Morco House Riverview Road Beverley HU17 OLD ENGLAND			

MORCO INSTANTANEOUS GAS WATER HEATER		CE 0099 99AT507	
Mod. N°:	D61B NAT		
Gas Type:	G-20 G-20/G25	20mbar	Cat. I _{2H} 20mbar Cat. I _{2E+} 25mbar
Type:	B _{11B5}		
Qn (hi)	11,1 kW		
Qm (hi)	6,6 kW	R. Fab. 20/26210	
Pn	9,4 kW	SERIAL N°	
Pw	10 bar		
Cat.	I _{2H}	I _{2E+}	BE / FR
Country/Pays:	ES / GB / IE / IT / PT		
USE ONLY IN WELL VENTILATED ROOMS NOT TO BE INSTALLED IN BATHROOMS			
MORCO PRODUCTS LTD Morco House Riverview Road Beverley HU17 OLD ENGLAND			

OPERATING DIAGRAM

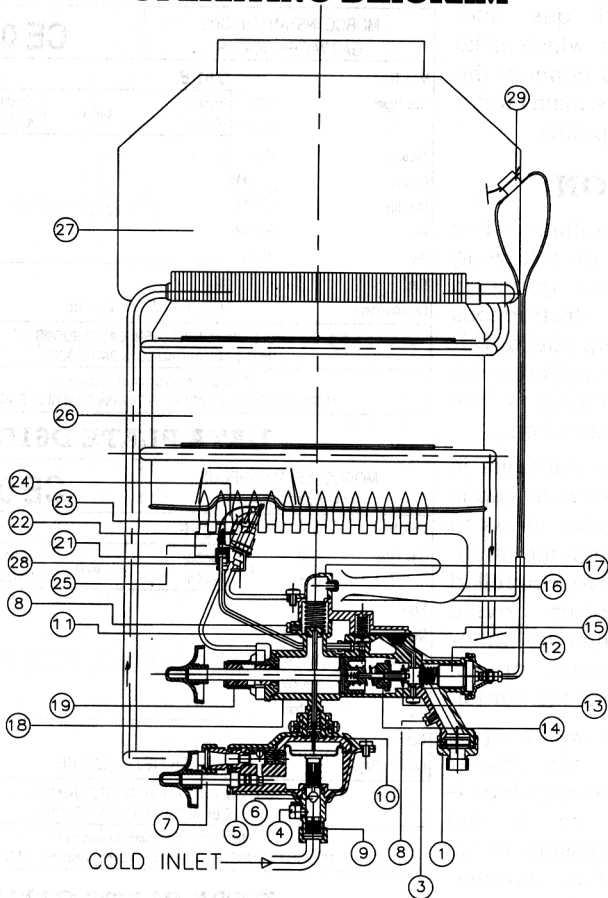

- 1- GAS SUPPLY CONNECTION
- 3- GAS FILTER
- 4- DRAIN PLUG
- 5- LOWER PROTECTOR
- 6- WATER FLOW REGULATOR
- 7- WATER TEMP. SELECTOR
- 8- INLET PRESSURE NIPPLE
- 9- WATER FILTER
- 10- UPPER PROTECTOR
- 11- MAIN BURNER GAS VALVE
- 12- MAGNETIC VALVE
- 13- HI/LO GAS SETTING
- 14- INTER-IGNITION VALVE
- 15- PILOT VALVE

- 16- BURNER JET
- 17- MAIN BURNER BAR
- 18- MAIN GAS VALVE BODY
- 19- SPINDLE ASSEMBLY
- 21- PILOT INJECTOR
- 22- SPARK ELECTRODE
- 23- THERMOCOUPLE
- 24- PILOT BURNER
- 25- MAIN BURNER
- 26- HEAT EXCHANGER
- 27- DRAUGHT DIVERTER HOOD
- 28- PILOT SECURING NUT
- 29- C.P.D.S.D. (SPILAGE SAFETY DEVICE)

A.2.2. - INSTALLATION INSTRUCTIONS

• RECOMMENDATIONS

For the user

The appliance must be installed, adjusted or adapted for use with another type of gas only by a qualified and competent person.

It is both the quality as well as the correct installation which will ensure that your heater works properly.

For the installation engineer

A.2-2-A RELATED DOCUMENTS

The following British Standards, Codes of Practice and other Regulations must be observed in the installation of the water heater.

The Gas Safety Regulations (Installation and Use) 1998

The Model Water Byelaws

Byelaws of the Local Water Undertaking

The Building Regulations (Permanent Buildings) England and Scotland.

BS 5482 Part 1 Installations in Permanent Dwellings

BS 5482 Part 2 Installations in Caravans and Non-Permanent Dwellings

BS 5482 Part 3 Installations in Boats

BS EN 1949 Installation of LPG System for Habitational Purposes in Leisure Accommodation Vehicles

EN 721 Leisure Accommodation Vehicles - Ventilation Requirements

Location:

The water heater requires a plentiful supply of fresh air for correct operation. Fixed ventilators or air inlets should not be obstructed.

Do not install the water heater in a location where incomplete combustion is foreseeable.

IE In bathrooms or bedrooms unless specifically allowed by national legislation.

The minimum ventilation free areas are stated in this manual and must be observed.

The water heater must be fixed to a load bearing wall in a vertical plane.

The water heater should not be installed adjacent to combustible materials, either above or at the sides or rear, if the temperature of those surfaces could otherwise exceed 65°C based in an ambient temperature of 15°C. In such cases a heat shield must be installed in the form of a fabrication from sheet metal mounted away from such surfaces to allow a minimum air gap of 25 mm.

• COMBUSTION GAS REMOVAL

Flue: A draught diverter is fitted to the top of the water heater. The nominal flue size is 90 mm. (D61B, D61E) and 110 mm. (G11E). In exposed situations, twin-walled flue pipe should be used. A minimum length of vertically rising flue of 600 mm. must be provided to ensure the water heaters products of combustion are completely evacuated. If single wall flue pipe is being used which has to pass through combustible materials, provide a metal sleeve of 115 mm. diameter which allows an air gap of 25 mm.

The flue shall not run into chimneys for removing combustion products from solid or liquid fuels. Flue pipes and terminals should comply with BS 715. Terminals shall not be sited within 300 mm. of a ventilator or open window. In the U.K. full details of flueing requirements are given in BS 5440 Part 1.

The flow rate of the combustion gases is 14 m³/h (G-30 and G-31) and 14.54 m³/h (G-20 and G-25). The temperature of the combustion gases at the exit draught diverter hood is 137°C (Model D61E, D61B).

The flow rate of the combustion gases is 41.4 m³/h (G-30 and G-31) and 44.4 m³/h (G-20 and G-25). The temperature of the combustion gases at the exit draught diverter hood is 160°C. (Model G11E).

This appliance is fitted with a safety device to monitor the removal of combustion gases, which cuts off the supply of gas to the burner, thereby turning off the appliance.

The function of this device is to detect (thermally) if products of combustion are not being removed to the outside air by the flue, due to adverse weather conditions causing a down draught down the flue, blockage in the flue or problems with the ventilation supplying the air for combustion.

This device should never be deactivated or removed, as this would compromise the safety of the occupants in the event of flue gas spillage.

Whenever any repairs are made to this device, only original parts should be fitted. A check should always be made to ensure that the appliance works correctly. The procedure is as follows:

- a) Turn the appliance on.
- b) If air does not blow back through the flueway due to bad weather conditions (too much wind), the control device should not stop the appliance, at least during 30 minutes of continuous operation.

If this test is carried out satisfactorily, the appliance is in perfect operating condition.

If the appliance repeatedly turns off, this means that the combustion gases are not being removed correctly. The problem should be resolved by taking the appropriate steps.

• AIR SUPPLY FOR COMBUSTION

Air requirements: Reference is made to BS 5482 BS EN 1949 and EN 721 covering ventilation requirements for permanent dwellings, caravans and boats.

Fixed ventilation should be provided to avoid draughts as far as possible without impairing the free area of ventilation, even in adverse weather conditions. If the heater is positioned in location which may be subjected to strong draughts i.e. close to a window or opening then strong draughts or gusts of wind may extinguish the pilot.

All permanent openings for ventilation should be designed to prevent the entry of vermin. Where screens are provided, they should not have apertures of less than 6 mm. or greater than 9 mm. in any direction, and they should be accessible for cleaning. Fine mesh screens shall be avoided as they are liable to become blocked with dust.

The location of vents and the method of cleaning them should be stated in the Owners Handbook (Caravans and Boats).

As a guide, the minimum effective free area of vents is stated below in connection with this water heater. Additional appliances burning gas in the same area would require additional air requirements.

1. If a D61B, D61E or G11E is installed in an enclosed space in a Caravan Holiday Home the required ventilation is that as specified in BS 5482 part 2, i.e. 10 cm² per kilowatt input rating divided between high and low. So the high and low should be 55.5 cm² for the D61B, D61E and 113 cm² for G11E.
2. Where a D61B or D61E is installed in an open bottomed cupboard in a Caravan Holiday Home, i.e. in a kitchen, the ventilation requirements are as stated in BS 5482 part 2. (EN 721).

A.2.2.B PUTTING AN APPLIANCE INTO SERVICE

Checks:

Check that the main water and gas supplies meet the specifications given on the appliances technical specification plate. Take special care to ensure that the water and gas pressures are correct. Also make sure that the bottle regulator is large enough to allow sufficient gas to be supplied to the appliance, bearing in mind the gas consumption of other appliances on the same gas supply.

• FIXING THE APPLIANCE

To do this you only need to remove the cover. Proceed as follows:

- Remove the control knobs
- Remove the screw securing the front cover, hidden by the water temperature selector knob.
- Remove the cover from the lugs which secures it to the top of the back plate.

Having selected a location for the water heater in accordance with the requirements set out in this Manual, the water heater should be fixed to the wall using the mounting holes on either side of the base plate.

• PUTTING THE APPLIANCE INTO SERVICE

- Before connecting up the appliance, it will be necessary to purge the water and gas pipework thoroughly, in order to remove filings and other debris.
- Connect the 3/4 inch BSP gas coupling/ valve to the appliance, ensuring that the supplied washer is in place. Gas jointing paste should NOT be used as this is likely to cause a blockage to the gas inlet filter which will affect the performance of the water heater.
- Connect the water inlet and outlet pipes to the appliance. Cold to the water control assembly and hot to left hand side of heater.

- Ensure that all the washers are properly fitted.
- Ensure all gas and water joints are sufficiently tight as not to leak.

• **WATER TIGHTNESS OF THE WATER CIRCUIT**

Allow water to flow into the heater by slowly turning on the water supply to the appliance. This will prevent possible damage due to hydraulic shocks on high pressure water supplies. Purge air from the water pipes by slowly turning on all the hot and cold water taps. Turn off the taps and check for leaks around the heater.

• **GAS TIGHTNESS OF THE GAS CIRCUIT**

Connect a manometer to the inlet pressure nipple (Number 8 on Operating Diagram) and carry out a gas soundness test in accordance with the current procedure. Gas joints down stream of the magnetic valve which cannot be tested during soundness testing with the manometer should be checked with leak detection fluid with the appliance running.

• **STARTING UP THE APPLIANCE AND FINAL CHECKS**

Start the appliance by following the directions given in section 1, "Instructions for Users", checking that the appliance is working correctly. Pay special attention to the colour of the flames ensuring there is no yellowness which would indicate burner venturis blocked by insect matter.

Check the gas operating pressures with the heater under full power at the inlet pressure nipple located on the left hand side of the gas body valve stem (position 8) the pressure drop should not exceed 2.5 mb below that specified in this manual.

Check the burner pressure with the heater at full load at the test nipple located on the left hand side of the main gas valve body below the main burner. These pressures must at least be equal those specified in this manual in order to achieve the desired performance specified in this manual.

Check the flue for spillage; close all doors and windows in the room containing the appliance. If any fans are fitted within the room containing the appliance, test with the fan or fans on full.

Light any other open flued appliances contained within the room that may affect the flue operation.

Turn the appliance on full and run for 5 minutes to allow the flue to warm up.

Hold a smoke match in the side opening of the draught diverter using an extended holder, making sure the end of the match is located centrally in the draught diverter.

The smoke should be pulled up the flue and not back into the room.

If spillage is detected, run the appliance for a further 10 minutes and then repeat the test. If spillage is still detected, then check the flue for blockages, the correct flue and terminal is fitted and the correct size of ventilation is fitted.

These gas water heaters are set in the factory for use with the gas they are intended to burn. The gas for which each appliance is set is indicated on the packaging and on the cover of the heater itself.

Note: The jets to be used with the type of gas for which the appliance is intended will be supplied from the factory. Their diameters correspond to the following sizes: Ø in mm

MODELS	ø in mm.		
	GAS TYPE	BURNER	PILOT
D61B-D61E	PROP/BUTANE	0,72 (6 off)	0,19
D61B	Natural	1,35 (6 off)	0,32
G11E	PROP/BUTANE	0,72 (12 off)	0,19
G11E	Natural	1,18 (12 off)	0,32

A.2.3. - LOOKING AFTER THE APPLIANCE

• PRECAUTIONS

- Against furring up (lime scale)

If the appliance is installed in an area with very hard water, with time, the following may occur:

- A fall in the hot water temperature, or
- A reduction in the hot water flow.

This means that the heat exchanger may be furred up, creating the above situations. As the level of scale build up is proportional to the selected outlet temperature, (the hotter the water the greater the scale build up) In order to reduce scale build up it is recommended that the water temperature required at the outlet is achieved by selecting the desired temperature at the heater, and not by mixing the hot and cold water at the outlet to obtain the correct temperature i.e. for showering purposes.

Note: Defurring/descaling should be carried out using proprietary agent or dilute hydrochloric acid. It is recommended to circulate the descaling fluid around the heat exchanger in order to speed up the process. Depending on the amount of scale build up and the strength of the descaling solution used, the time to totally descale will vary.

• MAINTENANCE

• MINIMUM ANNUAL MAINTENANCE

Gas water heaters are rugged pieces of equipment which are designed to work for a long time with minimum maintenance requirements. The only regular maintenance required is the (annual) cleaning of the heating body and the burner. If the appliance is installed in a caravan or boat it is essential this is done at the beginning of each season.

• CLEANING THE MAIN BURNER

- To carry out the annual cleaning of the burner, proceed as follows:
- Turn off the gas supply, remove the cover and remove the burner.
- Clean the surface of the burner heads gently with a brush. Then blow through them to remove any particles of dust loosened during the brushing operation.
- Check the venturis for contamination from insects and spiders webs.

• **CLEANING THE HEAT EXCHANGER**

To carry out the annual cleaning of the heating body, proceed as follows:

- Turn off the gas supply
- Turn off the supply of water to the appliance by turning off the appliance's water inlet tap.
- Turn on all the hot water taps to empty all the pipes.
- Remove the heating body and clean it by gently brushing the fins. Soot if found should be removed by washing, and the cause of the sooting investigated.

• **CLEANING THE PILOT**

If the pilot light flame is yellow and the safety valve takes a long time to open, this means that either the pilot injector or pilot burner is partially blocked.

The pilot injector may be blocked with contaminants carried within the gas, whilst the pilot burner is more likely to be contaminated by insects (spiders / egg sacs)

N.B. No attempt should be made to clear blocked or partially blocked pilot injectors by using wire. If blowing through the injector fails to clear the restriction, then a new injector should be fitted.

When the pilot is working normally the flame should be a stable blue coloured cone shape. To clean the pilot burner, proceed as follows:

- Turn off the gas supply, remove the front cover. Remove the pilot injector, by slackening the supply pipe nut first, and unscrewing the pilot injector from the pilot burner
- Remove the contamination from within the pilot burner using wire, and blow through to remove any further debris.
- Replace the pilot injector, ensuring that the washers are properly fitted and test joints with leak detection fluid.

A.2.4. SYMBOLS

The meanings of the symbols used on the appliance and on the packaging are as follows:

Cat	: Appliance category
Qn	: Nominal gas flow rate according to Hi
Qm	: Minimum gas flow rate according to Hi
Hi	: Net calorific value

A.2.5 TROUBLE SHOOTING

Majority of the problems you will come across are usually caused by either gas supply, water supply, air supply or contamination of either!

Always carry out basic performance tests including operating pressure tests before jumping to the troubleshooting chart.

Be sure you are getting an accurate description of the symptoms before concluding the water heater is at fault. The charts assume a level of knowledge and competency and are there to serve as a guide and a prompt.

PROBLEM	CAUSE	ACTION
No spark.	The piezo electric ignitor is faulty. Electrode is fractured. Electrode is dirty. Spark gap is too wide. Incorrect battery polarity. Poor earth. Flat battery. Spark generator faulty.	Replace with new one. Replace with new one. Clean it with bristle brush, etc. Adjust the gap to 3.2-4.0mm. Check. Check. Check. Check.
Pilot fails to light.	Blocked injector. No gas supply.	Clean using soft bristle only. Check.
Pilot is difficult to light with spark.	The pilot injector is clogged. Air in gas line.	Clean or replace pilot jet. Depress the control button to ignition position long enough to expel all air. Purge gas supply through hob.
Pilot ignites but fails to stay alight.	The flame on pilot burner does not impinge on the thermocouple correctly. Loose thermocouple. Magnetic valve is faulty. Faulty thermocouple. The main control button is not fully depressed. C.P.D.S.D is faulty.	Clean or replace pilot jet. Re-position thermocouple. Check thermocouple for tightness. Replace with new one. Replace with new one. Press it down hard and hold that position for about 10 seconds. Replace it.
When main burner ignites, the pilot flame becomes much smaller.	Insufficient gas pressure.	Check operating pressure at burner and inlet. Check the whole gas supply line for blockages, including gas filter on the heater.
Main burner does not ignite even though hot water outlets have been turned on.	Insufficient water pressure. Faulty diaphragm in water control body assembly. Hot and cold water pipes crossed. Contamination in water control assembly. Water filter blocked.	Check water pressure at inlet to heater. Check for blockages in supply line or hot pipes, taps, shower hoses and heads. If using a pump, check pump for faults. Renew diaphragm. Check, re-connect correctly. Clean. Clean.

PROBLEM	CAUSE	ACTION
Main Burner ignites when temp. adjusting knob is positioned at "HOT" but goes out when turned down to "WARM" position.	Insufficient water pressure Water filter is clogged. Faulty diaphragm. Restriction in heat exchanger	Check water pressure at inlet to heater. Check for blockages in supply line or hot pipes and taps. If using a pump, check pump for faults. Clean. Renew diaphragm. Descale or replace.
Main burner fails to shut off when hot water taps are closed.	Dirt on main gas valve seating. Jammed water regulator. Contamination in water control assembly.	Inspect and clean. Inspect and clean. Clean or replace.
Main burner flames are yellow and lazy. NB Yellow tips on blue flame may be normal if appliance is running on butane.	Partly blocked burner venturis. (Insects and spiders). Gas flow rate too high. Heat exchanger sootied up and dirty.	Remove main burner and clean as necessary using stiff brush. Check gas pressure at the heater and adjust regulator to the correct range. Clean the heat exchanger.
On ignition, the burner makes an unusual noise. (Flash-back).	The position between pilot burner and main burner is not close enough. Gas pressure (flow rate) is insufficient. Gas supply line is too small in diameter. (Insufficient gas supply). Partly blocked main burner Injectors.	Adjust. Check operating pressure's at the burner and inlet pressure test points. Check the whole gas supply line for blockages including the gas filter on the heater. Check the gas regulator. Enlarge the gas supply pipe. Clean them.
Even though temp. adjusting knob is turned to "HOT" position, heated water is not hot enough.	Gas pressure (flow rate) is insufficient. Gas supply line is too small in diameter. (Insufficient gas supply). Partly blocked main burner injectors. Low water pressure.	Check gas cylinder regulator for faults and the supply pipe for blockages. Enlarge the gas supply pipe. Clean them. Check for restrictions. Improve pressure at mains.

PROBLEM	CAUSE	ACTION
Even though temp. adjusting knob is turned to "HOT" Position, heated water is not hot enough due to too high a water flow rate.	Water regulator is faulty. Faulty diaphragm in water control body assembly. Incorrect water control assembly fitted. Hot and cold water pipes crossed.	Inspect and clean. Replace with new one. Replace with correct type. Check, re-connect correctly.
Even though temp. adjusting knob is turned to "WARM" position, heated water is too hot due to a low water flow rate.	Water regulator is faulty. Water pressure is insufficient. Water filter is clogged. Incorrect water control assembly fitted. Heat exchanger restriction (damage or limescale)	Inspect and replace it. Check water pressure at inlet to heater. Check for blockages in supply line or hot pipes and taps. If using a pump, check pump for faults. Clean. Replace with correct type. Replace or descale.
Same as the above conditions due to long flame.	Too much volume of gas flow/ excessive gas pressure.	Check gas pressure at the heater and adjust regulator within the correct range.
Main burner and pilot flame goes out during operation.	Combustion spillage safety device has activated. None or insufficient ventilation fitted. Blocked ventilation Insufficient gas pressure.	Check flue for correct fitting, blockages or any damage to flue pipe or terminal. Check for spillage due to the effects of any fans or adverse weather conditions. Check the ventilation, referring to the appropriate standard. Unblock ventilation, (advise the importance of ventilation). Check operating pressure's at the burner and inlet pressure test points. Check the whole gas supply line for blockages including the gas filter on the heater. Check the gas regulator.
Main burner only goes out during operation.	Gas pressure (flow rate) is insufficient. Gas supply line is too small in diameter. (Insufficient gas supply). Partly blocked main burner injectors. Low water pressure and reduced flow rate due to other cold water outlets in use at same time as heater. Water filter blocked. Diaphragm faulty.	Check gas cylinder regulator for faults and the supply pipe for blockages. Enlarge the gas supply pipe. Clean them. Check water pressure at inlet with water heater in operation. Plumbing modifications may be necessary to installation. Clean or replace. Replace diaphragm.

PROBLEM	CAUSE	ACTION
Water heater operates at taps but not at shower.	Shower hose too small or kinked. Shower head restricted. High water pressure. Low water pressure. Shower mixer tap faulty or not set correctly.	Replace. Descale, remove blanking rings or replace. Restrict cold water supply to shower mixer. Set shower temperature at water heater rather than mixing cold water at mixer. Set correctly or replace
Water control assembly leaks from between flanges.	Frost damage.	Replace damaged parts.
Water control assembly leaks at spindle, outlet union, or inlet union.	Frost damage or contamination of O rings.	Clean or replace.
Soot deposits on front cover and smell of fumes.	Blocked burner venturi and sooted blocked heat exchanger.	Remove burner and heat exchanger and clean thoroughly.

A.2.6. WARRANTY

The water heater is guaranteed against manufacturing defects for one year from first commissioning. However the guarantee is subject to proof of commissioning in accordance with the gas safety (Installation and Use) act of 1998. The guarantee does not cover defects caused by lack of maintenance see section 2.3.

Manufactured in Spain by Fagor Electrodomésticos.

Distributed in the U.K. by:

MORCO PRODUCTS LTD

Morco House
Riverview Road
Beverley
East Yorkshire
HU17 0LD
ENGLAND

Telephone Number: 01482 325456

Fax Number: 01482 212869

Web Address: www.morcoproducts.co.uk